



ANNEX 1.1

iMERMAID Technical Specification

Open Call #2 Extended Demonstration of the iMERMAID solutions in new associated regions

Submission deadline: 03 April 2025, 17.00 CEST

Disclaimer

Any dissemination of results reflects only the author's view, and the European Commission is not responsible for any use that may be made of the information it contains.

© iMERMAID Consortium, 2023

This deliverable contains original unpublished work except where clearly indicated otherwise. Acknowledgement of previously published material and of the work of others has been made through appropriate citation, quotation, or both. Reproduction is authorised provided the source is acknowledged.

Copyright message



**Funded by
the European Union**

Table of Contents

No table of contents entries found.

LIST OF TABLES

Table 1 - Electrochemical sensor box for microorganic pollutants	6
Table 2 - Heavy metal sensor	7
Table 3 - PFAS sensors for monitoring water contamination	8
Table 4 Oil spills monitoring based on Sentinel - 1 satellite data	10
Table 5 - Microfluidic water remediation system	12
Table 6 - HiNaPEF Pulsed Discharge Plasma	13
Table 7 - 4D Scavenger for removal and recovery of heavy metals	15
Table 8 - A non-destructive characterization & treatment system of fouled end-of-life reverse osmosis (RO) modules	16
Table 9 - iMERMAID Toolkit for end user engagement and social impact	17
Table 10 - Blockchain Traceability Compliance Labelling (TCL)	19
Table 11 – Data analysis based on remote satellite images applied to local scenarios	21
Table 12 - iMERMAID Use-case checklist	28

Acronyms

BWRO	Brakish Water Reverse Osmosis
CoEC	Contaminants of emerging concern
LoD	Limit of detection
OC	Open Call
PDP	Pulsed Discharge Plasma
PFOA	Perfluorooctanoic acid
PFAS	Polyfluoroalkyl substances
SWRO	Sea Water Reverse Osmosis Plants
TCL	Traceability Compliance Labelling
UC	Use case
WWTP	Waste water treatment plant

1.0 Introduction

The aim of **iMERMAID Open Call #2**, entitled "**Extended Demonstration of the iMERMAID solutions in new associated regions**," is to engage additional use-cases to replicate the iMERMAID solutions in regions not currently participating in the iMERMAID project. The selected beneficiaries will receive capacity building support and technical guidance to implement projects (also referred to as extended use-cases) that are aligned with the iMERMAID objectives and goals and that will showcase the feasibility, replicability, and scalability of the iMERMAID solutions. As a reminder, proposals addressing the domains already tackled in the internal iMERMAID project use-cases can be the same but need to be executed in a different region.

Under this granting scheme, the beneficiaries are local and/or regional authorities from associated regions.

For Open Call #2 iMERMAID will allocate EUR 500,000 to be distributed among up to five successful applications.

This document, referred to as ANNEX 1.1 Technical Specification, offers a comprehensive outline of:

- The iMERMAID methodology,
- iMERMAID innovative solutions,
- iMERMAID Use-case specifications check-list.

The information provided is designed to assist third parties in developing their action as described in their proposals (Annex 2). This document should be considered as an extension of Annex 1 – iMERMAID Guidelines for Applicants.

2.0 The iMERMAID Methodology

The iMERMAID project aims at monitoring, reducing and remediating the Mediterranean Sea against chemical pollutants. To this end, it establishes a series of key actions on which the results of the project will be based, such as:

- i) **sensors & digital tools** for the identification and measurement of chemical pollutants
- ii) **innovative technologies** for their removal
- iii) **demonstration sites** where the combined operation of sensors and technologies can be presented.
- iv) raise awareness of the importance of chemical pollutants through **social perception assessment**

Implicitly, the objective of the open calls is to replicate these same results in other regions, using the iMERMAID methodology, which consists of analysis of the environment, development and validation of solutions, and as an outcome - adoption of these solutions by stakeholders, with the aim of improving the current water management scenario of the Mediterranean Sea basin in any aspect (social, technological, environmental...).

In this way, the participation of third parties will enrich the results of the project and will be a source of synergies. On the one hand, improving the quality of the project results, deepening the knowledge of the implemented solutions by having a wider range of regions with their own particularities, and on the other hand, facilitating advice and access to innovative improvement solutions to third regions that would otherwise have to go through a much more complex path to obtain this type of technologies by themselves.

3.0 iMERMAID innovative solutions

The current section presents the iMERMAID solutions, available to third parties to assess and implement based on their use-case needs. Third parties can identify individual and groups of solutions. It is expected that during the first stage of the iMERMAID programme the use-case - solution fit will be elaborated in the selected beneficiaries' Individual Mentoring Plans, with the support and guidance of the assigned mentors.

Sub-section 3.1 presents solutions for monitoring and prevention, sub-section 3.2 addresses solutions for remediation and sub-section 3.3 highlights solutions for community engagement, including end user assessments and public awareness initiatives for Contaminants of Emerging Concern (CoEC). When reviewing the solutions please be mindful of what is stated as explicitly available within the "Access During FSTP Programme" and what is advisable to be conducted as "Preliminary Actions" from the third party projects for the selected solutions.

3.1 Solutions for chemical pollution monitoring and prevention

Table 1 - Electrochemical sensor box for organic micropollutants

Electrochemical sensor box dedicated to organic micropollutants (i.e., pesticides, pesticides residues, drugs, pharmaceuticals, agroindustrial compounds)

Technical Description

The electrochemical sensor box is an apparatus combining few electrochemical sensors developed for onsite experiments and real time analysis of organic micropollutants (i.e., bisphenol A, , Ibuprofen...).

Image



<p>Application</p>	<p>The end user will easily use the electrochemical sensor box to facilitate the diagnosis of their process of remediation. In contrast with laboratory analysis that can't be obtained daily, the deployment of the electrochemical sensor box allows for daily monitoring providing reliable and timely results. The electrochemical sensor box is ideal to be deployed in conjunction with a remediation solution, as it can assist the evaluation of its effectiveness.</p>
<p>Ideal End-User</p>	<p>The electrochemical sensor box is ideal for operators in water treatment plants and/ or on isolated sites.</p>
<p>Preliminary Actions</p>	<p>The preliminary work to be done is to identify the targeted molecules, their concentration level and to study the matrix feasibility of the electrochemical analysis (wastewaters, seawaters, storm waters) Based on the known targeted molecules list we can know if the electrochemical sensor box can be used. Third parties interested in this solution should conduct the preliminary activities and as an outcome in the third phase the exploitation plan for solution adoption will be developed with the support of the assigned technical mentor.</p>
<p>Access During FSTP Programme</p>	<p>Full access to the technology is available. Technicians endorsed in water analysis will be able to acquire the practice of such technology. Courses will be deployed to help if necessary.</p>

Table 2 - Heavy metal sensor

<p style="text-align: center;">Heavy metal sensor</p>	
<p>Technical Description</p>	<p>The heavy metal sensor consists of an electrochemical system equipped with a properly modified sensor to make it sensitive to the presence of trace heavy metals (LOQ of around units of ppb). Heavy metals can be monitored by using stripping voltammetry, a fast electrochemical technique. Electrochemical measurements are performed by combining the heavy metal sensors with a miniaturised portable potentiostat, equipped with a suitably developed software. The complete measurement cycle requires between 5 and 10 minutes as execution time, depending on the sensitivity that must be achieved. The cleaning process includes a final check to evaluate the reusability of the sensor. After measurements, raw data coming from the voltametric</p>

measurements can be processed to obtain the heavy metal concentration. This can be done by means of a calibration curve obtained for each tested metal (by applying the sensor in standard solutions), or by using the standard addition method during sample analysis and related calculation.

Image



Application

The sensor for heavy metal detection is a portable system developed to be applied for on-site monitoring of heavy metals as well as Zinc, Cadmium, Lead and Copper, at ppb levels.

Ideal End-User

People and entities (public and private) that need to monitor heavy metal content in waste waters.

Preliminary Actions

An appropriate filtration process prior to sample analysis must be applied. A pre-condition step for sensor stabilization is needed before analysis. Calibration curves in standard solutions must be performed at first to evaluate the sensitivity of the system for each of the heavy metal to be tested.

Access During FSTP Programme

Expertise available for feasibility assessment. Protocols for sample treatment and analysis for the determination of heavy metals in waste waters, and analytical skills for data interpretation will be provided.

Table 3 - Perfluoroalkyl and polyfluoroalkyl substances (PFAS) sensors for monitoring water contamination

PFAS sensors for monitoring water contamination

Technical Description

Sensor for the PFAS monitoring is to be of standard electrochemical type, with screen-printed graphene as working and counter electrodes, and silver/silver chloride reference electrode. It provides rapid response time in measurements with small sampling volume (of water susceptible to PFAS pollution) and through a low-cost protocol, with the general working principle schematically given on the images provided below.

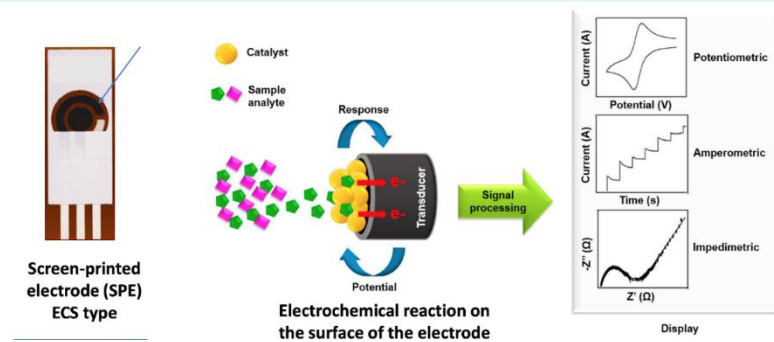

Image



Application

Main focus is on the detection of PFOA (Perfluorooctanoic acid) as a specific compound of interest from the PFAS family, commonly found in surface water, groundwater, soil, as well as in aquatic, soil and land biota organisms across Europe. It is currently mostly phased out of production processes as carcinogenic, but remains highly persistent and non-degradable in nature, resistant to extreme pH, oxidants, and microbes.

	<p>Targeted limit of detection (LoD) is around 1µg per litre, attained with the support of the integrated high-quality signal processing module in the device, while the embedded (mobile/cellular data) communications module enables remote acquisition or reading of measurements, and firmware updates and control.</p>
<p>Ideal End-User</p>	<p>National or regional/local environmental protection or monitoring authorities (ministries, agencies), public health authorities, agricultural or veterinary authorities, communal public enterprises, or any other concerned with water pollution/quality or its spread to soil and living organisms. Sampling can be performed on any water body or related installation (drinking water, wastewater, etc.).</p>
<p>Preliminary Actions</p>	<p>Generally, just secure data connectivity (https internet access) is required on monitoring/sampling sites controlled by the selected beneficiary, to be able to upload the measurements data onto the iMERMAID platform in real- or near real-time (and use the provided visualizations dashboard).</p>
<p>Access During Programme</p>	<p>FSTP</p> <p>The open call applicant can propose using the sensors in their project to monitor the PFAS pollution in their region. PFAS sensors can be deployed in the water to monitor in real-time a number of molecules. The results of detection are visualised over the dashboard, which will be provided free with the access to the user. The limited number of sensors will be developed during the project to support at least one open call project. The solution should be available from January 2025 onwards.</p>

Table 4 Oil spills monitoring based on Sentinel - 1 satellite data

<p>Oil spills monitoring model based on Sentinel-1 satellite data</p>	
<p>Technical Description</p>	<p>To achieve iMERMAID project goals a deep learning model LinkNet has been trained using satellite-based data from Marine Pollution Surveillance Reports to detect oil spills. This model is designed to identify and monitor oil spills. It comes with all the necessary components, including the model weights (which are the learned parameters) and the Python code required to run the model.</p> <p>To manage and process the large amounts of data involved, the LinkNet model needs to be used in a cloud environment. This means running the model on powerful, remote computers that can handle big data efficiently. For example, using Google Colab with a Tesla T4 GPU (a specialized graphics processing unit) would allow the model to perform the complex calculations quickly and accurately.</p>

Image

LinkNet model architecture

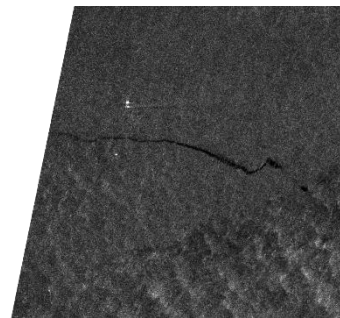
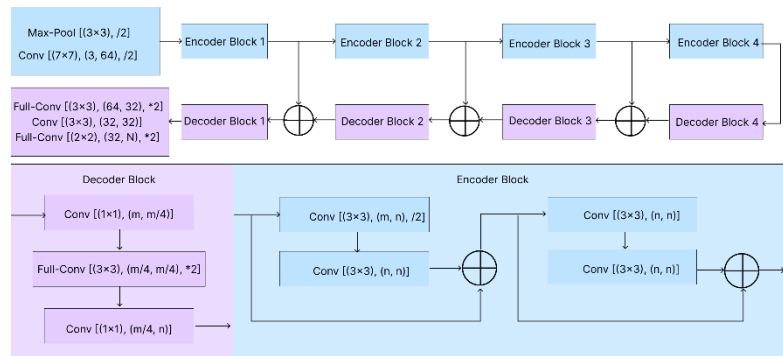

Input SAR image

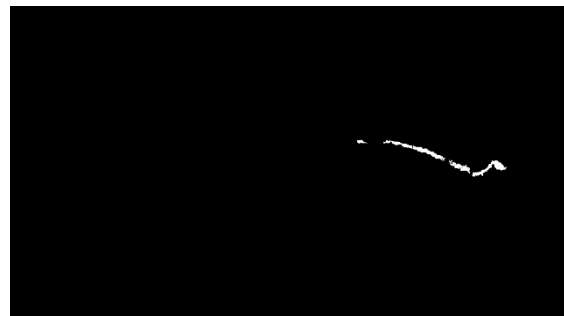

Output segmentation result. White - oil spill; Black - not oil spill

Application

The model can be used for oil spill detection in marine environments. Upon availability of the Sentinel-1 VV-polarized SAR data, the model can provide the segmentation result of oil spill detection in the form of GeoTIFF raster file.

Using a pretrained model the 20-megapixel (roughly 6200x3500) image is segmented approx. within one minute. At the moment of training the model using a previously formed dataset (270 640x640 images, 1 GB space) requires about 40 mins on the basis of GPU-enabled hardware.

Ideal End-User

The solution would be ideally suited for environmental agencies, coastal authorities, research institutions, and environmental consultancies involved in monitoring and managing marine oil spills. End users must be familiar with satellite data processing, AI models and cloud computing.

Preliminary Actions	Third parties can be provided with a raster map on demand (GeoTIFF format) with the results of oil spills identification for further analysis and usage. In case of further model usage the third parties should have AI/IT specialists and data analysts.
----------------------------	--

Access During FSTP Programme	Expert assistance for model usage, including input data preparation, model execution and interpretation of results. Assistance in training and fine tuning on new or additional data
-------------------------------------	--

3.2 Chemical pollution remediation solutions

Table 5 - Microfluidic water remediation system

Microfluidic water remediation system

Technical Description	<p>The Microfluidic water treatment system represents an innovative bioinspired technology, serving as an advanced tertiary solution for the restoration of contaminated waters. While conventional microfluidic systems are typically associated with handling minute volumes of water, often measured in microliters or nanoliters, our system breaks this mold by efficiently processing large quantities, reaching several thousand liters per day.</p> <p>Microfluidic water remediation system is a compact, low energy consumption water treatment solution targeting micropollutants, dedicated to tertiary treatments. It consists of microfluidic CDs engraved with the microfluidic networks, which can operate at a high flow rate and can be easily deployed in various treatment facilities. The microfluidic channels enhance the efficiency of the degradation agents by confining them in a micro realm thereby enhancing the pollutant-degradation agent encounter and enabling ultra-fast reactions.</p>
Application	<p>The solution is a tertiary water treatment system aimed at degrading organic micropollutants. The system requires a prefiltration system to remove any suspended solids that could affect with the normal functioning of the system.</p>
Ideal End-User	<p>Wastewater treatment plants, municipalities and other bodies managing the wastewater treatment facilities, Industries requiring water treatment facilities, facilities involved in water reuse.</p>

Preliminary Actions	<p>The open call applicant can carry out analysis on water quality to measure total organic content (TOC), total suspended solids (TSS), and identify prevalent micropollutants (e.g., pharmaceuticals, pesticides, industrial chemicals) along with their concentrations.</p> <p>A feasibility study which could provide information on the technical feasibility to determine the compatibility of the microfluidic system with existing treatment processes and infrastructure.</p> <p>Furthermore, the applicant can carry out operational and economic feasibility studies for the potential deployment of the solution.</p>
Access During FSTP Programme	<p>Expertise available for feasibility assessment; mentorship directly from the developers for the studies; site visit during the demonstration activities within the internal iMERMAID use-cases.</p>

Table 6 - HiNaPEF Pulsed Discharge Plasma

High Voltage Nanosecond Pulsed Electric Field (HiNaPEF) Pulsed Discharge Plasma

Technical Description	<p>Pulsed Discharge Plasma (PDP) is an advanced water treatment technology that uses high-voltage electrical discharges to generate plasma in water. This plasma creates various highly reactive species such as radicals, ions, and UV light, which degrade pollutants without additional chemicals.</p> <p>The PDP system typically consists of a reactor with two electrodes, often arranged in a point-to-plane configuration where a pointed anode faces a flat or cylindrical cathode. A high voltage pulse (e.g., 120 kV) applied between the electrodes creates a strong electric field that ionizes water molecules, forming plasma. This electric discharge splits water molecules into reactive species like hydroxyl radicals, hydrogen peroxide, and ozone, which are highly effective at oxidizing organic pollutants. The process also generates UV light, enhancing the breakdown of contaminants.</p> <p>These reactive species react with pollutants such as dyes, pharmaceuticals, and other organic compounds, breaking down complex molecules into smaller, less harmful compounds, or mineralizing them into carbon dioxide and water. Key parameters like pH, conductivity, temperature, and total dissolved solids (TDS) are monitored before, during, and after treatment to evaluate efficiency and optimize conditions. The frequency of the pulses and the distance between electrodes can be adjusted to optimize the degradation process based on the specific type and concentration of pollutants.</p> <p>PDP operates without external chemical agents, as the reactive species are generated by the plasma itself. It consumes up to 30% less energy</p>
-----------------------	--

	<p>compared to traditional water treatment technologies and reduces the formation of secondary pollutants, making it a more sustainable option.</p>
<p>Application</p>	<p>The PDP system is designed to address a broad spectrum of recalcitrant organic contaminants commonly present in industrial effluents. Applications extend to the removal of non-biodegradable and persistent pollutants—including pharmaceutical residues (e.g., antibiotic molecules or endocrine disruptors), stable pesticides, nitrosamines, surfactants, and synthetic dyes—that remain largely unaffected by conventional biological or physicochemical treatments. Beyond mere pollutant abatement, the technology can be integrated as a polishing step following established primary and secondary treatment operations or serve as a stand-alone advanced oxidation process.</p>
<p>Ideal End-User</p>	<p>The ideal end users of PDP technology are those stakeholders seeking advanced, energy-efficient solutions for tackling highly persistent and complex contaminant profiles. Industrial wastewater treatment facilities within sectors such as pharmaceutical manufacturing, agrochemical production, textile dyeing, specialty chemical synthesis, and food processing can leverage PDP to achieve compliance with evolving environmental standards while reducing both operational costs and greenhouse gas emissions. Municipal and regional wastewater utilities responsible for safeguarding public health and ecosystems will find the PDP platform particularly valuable for addressing emergent contaminants that elude traditional treatment regimes. Similarly, water-intensive industries striving to reuse treated effluent or meet circular economy objectives will benefit from PDP’s ability to enhance the biodegradability of residual streams and thereby facilitate subsequent biological or tertiary treatments. In essence, the ideal PDP end-user is any entity—public or private—that requires robust, adaptive, and sustainable treatment methods to manage complex wastewater matrices, meet regulatory benchmarks, and continuously improve the environmental quality of their effluent discharges.</p>
<p>Preliminary Actions</p>	<p>Applicants can conduct a feasibility study to assess the technical compatibility of the PDP system with existing processes and infrastructures. Furthermore, a technical assessment on the adequateness of the solution, evaluating physico-chemical parameters such wastewater conductivity and contaminants concentrations should be performed.</p>
<p>Access During FSTP Programme</p>	<p>Beneficiaries will have access to full application of the PDP technology. Feasibility study on selected use case and mentorship.</p>

Table 7 - 4D Scavenger for removal and recovery of heavy metals

4D Scavenger for removal and recovery of heavy metals

<p>Technical Description</p>	<p>4D Scavenger (4DS) is a novel system for selective recovery of valuable and removal of hazardous metals from industrial wastewater. The technology provides a customizable but easily applicable product for various water treatment-related problems. Compared to existing solutions, our technology combines unprecedented selectivity with faster reaction kinetics. This reduces the cost of metal recovery by up to 50% and thus makes the recovery of metals financially feasible for more types of metals, industrial processes, and smaller companies.</p>
<p>Image</p>	
<p>Application</p>	<p>4D Scavenger technology can help solve both environmental and commercial problems associated with dissolved metals or ions. By incorporating it into existing processes, 4DS can extract metals for reuse or remove previously hard or impossible to remove metals. It offers a scalable technology for recovering any metal from industrial and municipal wastewater. The filtering systems have virtually no limitations on recoverable metals, are effective for low concentrations (<0.1 mg/l), and boast a 99%+ recovery rate with high throughput.</p> <p>Typically, the treated wastewater becomes less toxic, leading to lower disposal costs, simplified regulatory compliance, and new opportunities for reuse.</p>
<p>Ideal End-User</p>	<p>Solution can be applied by anyone with metal containing waste or process water. Water treatment in mining industry (active and closed mines), metal refining and chemical industry is the typical use case but leachate treatment from for example landfills or metal recycling yards is viable.</p>
<p>Preliminary Actions</p>	<p>The feasibility of 4DS solution is evaluated based on water analysis results (metal concentration, suspended solids, pH etc.) and flowrate. This information can provide signal to continue testing in laboratory with subsequent onsite piloting. Third parties can complete studies to evaluate the potential of 4D Scavenger in various heavy metal recovery</p>

or removal needs. Technical feasibility can be estimated by the water parameters such as metal content, flowrate, other impurities and integrability with current treatment system.

Access During FSTP Programme

Expertise and 4DS feasibility assessment are available for beneficiaries. Laboratory testing by the developer of the solution - Weeefiner can be arranged on selected use cases. Onsite piloting possible as follow-up project for the most promising applications.

Table 8 - A non-destructive characterization & treatment system of fouled end-of-life reverse osmosis (RO) modules

A non-destructive characterization & treatment system of fouled end-of-life reverse osmosis (RO) modules

Technical Description

A cost efficient system for regenerating membrane modules. The technical solution combines treatment and characterization techniques relying on assessing flow hydrodynamics within membrane modules. This will allow extending life expectancy of fouled membrane modules thus significantly reducing operating costs. The technique is implemented in dedicated pilot systems that are capable of: i) Unfolding fouling extent of end-of-life membrane modules; ii) define fouled modules cleaning protocols for reutilization in the original application; iii) define end-of-life modules cleaning and/or treatment protocols for milder separation performances; iv) define best operating conditions of regenerated end-of-life membrane modules; v) implement performances characterisation, cleaning and treatment protocols.

Image

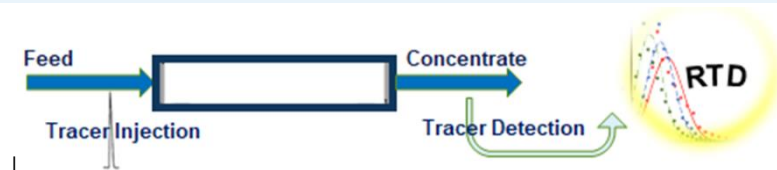

Application

The pilot system could be used to clean and or treat any fouled Seawater or Brackish Water Reverse Osmosis membrane modules (SWRO & BWRO). Mainly most used 8" membrane modules can be handled. However, the system can be graded to accommodate any RO and NF membrane module types and sizes. As for the internal iMERMAID use-case (Use-case 2), fouled membrane modules will be characterized and treated for reuse in the prefiltration of a pharmaceutical wastewater prior to the microfluidic enhanced oxidation system.

Ideal End-User

SWRO & BWRO desalination plants and units, Power plants, any industrial activity integrating membrane modules for handling and treating solutions.

Preliminary Actions

Open call applicants could conduct investigations on life expectancy of membrane modules with respect to their use and identify fouling matter by conduction membrane process simulations and performing autopsies of end-of-life modules. They could request preliminary characterization, cleaning and treatment tests of fouled modules allowing assessing the benefits of the advocated pilot system.

Access During FSTP Programme

Expertise and feasibility assessments are available for applicants. Operational system, site visits and demonstration activities are also offered to beneficiaries. ENIG will be fully engaged with applicants in mentoring a customised technical solution for the best-foreseen implementations.

3.3 Public acceptance and community engagement

Table 9 - iMERMAID Toolkit for end user engagement and social impact

iMERMAID Toolkit for end user engagement and social impact

Technical Description

The iMERMAID Toolkit provides a collection of approaches and instruments for community engagement at a local scale. The engagement activities are geared towards the reduction of chemical marine pollution caused by contaminants of emerging concern (CoECs). The target audiences of the Toolkit include: (1) citizens of the iMERMAID use case regions and (2) regional stakeholders (including private end-users), relevant to the iMERMAID’s use case regions. The Toolkit can be utilised for other audiences as well, beyond the ones identified for the needs of the iMERMAID project.

Image

Tool	Dimension	Phase of Engagement	Aim of the Tool	Audience or scale
Collaborative Stakeholder Mapping	Stakeholder engagement	Mapping & idea (co-) creation	Collaborative Stakeholder mapping and co-creation	Regional or topic selected stakeholders
Future Radar	Stakeholder engagement	Mapping and idea (co-)creation	Understand driving forces	(project) partners & direct stakeholders
Experiencing Futures	Stakeholder engagement		Understand plausible futures	(project) partners & direct stakeholders
Social Media Campaign(ing)	Citizen Engagement	Throughout	Change perceptions & knowledge transfer	All, focus on younger generation active on social media
Game Based Knowledge Transfer	Stakeholder engagement and capacity building	Focused review & conceptualisation	Stakeholder engagement and knowledge transfer	(project) partners & direct stakeholders
Flows of Knowledge (tool)	Capacity Building	Throughout	Qualitative Impact Assessment	All
Lego Serious Play	Stakeholder Engagement	Throughout	Strategy, Augmented collaboration, knowledge transfer	All
HowSpace	Stakeholder Engagement	Mapping & idea co-creation; Focussed review & conceptualisation, follow-up on joint project	Unbiased & unsynchronized online/ digital collaboration	(project) partners & direct stakeholders
Intergenerational workshops	Capacity Building	Throughout	Collaboration and capacity building support	(project) partners & direct stakeholders
Schooling projects	Citizen engagement & Capacity Building	Mapping & idea co-creation; Focussed review & conceptualisation, follow-up on joint project	Change perceptions and knowledge transfer	Schoolteachers, with focus on local/ regional high school classes (connection via the partner organisations) and their stakeholders
EWP (integrated leadership program for young professionals)	Capacity Building	Throughout	Community Building, Knowledge Transfer, change perceptions	(project) partners & direct stakeholders
BIT (integrated advanced leadership program)	Capacity Building	Throughout	Community Building, Knowledge Transfer, change perceptions	(project) partners & direct stakeholders
InterVision (Peer-to-Peer Coaching)	Capacity Building	Throughout	Community Building, Knowledge Transfer, change perceptions	(project) partners & direct stakeholders
Deep Democracy	Stakeholder engagement & augmented collaboration/ decision making	Throughout	Community Building, Knowledge Transfer, change perceptions	(project) partners & direct stakeholders

Application

Open call beneficiaries can utilize the tools for stakeholder and citizen engagement, which are crucial for validating iMERMAID solutions, gathering stakeholder feedback, and raising public awareness about CoECs, their impact on the environment and the ways non-expert audiences contribute to the challenges and the solutions at the local scale. These stakeholder engagement activities can be particularly relevant in Stage 2 and Stage 3 of the iMERMAID technical support program, during the implementation, evaluation, and feedback phases of the extended use-case projects.

Ideal End-User

Public authorities engaging a diverse range of stakeholders

Preliminary Actions

If events are anticipated they must be included in the applicant’s proposal, taking into account resource requirements and timing. Typically, one to two participatory events should suffice in order to: obtain feedback on the selected iMERMAID solutions and engage the broader public in understanding the importance of reducing and eventually eliminating the impact of CoEC and what is their role in achieving this objective.

Access During FSTP Programme

The selected third parties will have access to the toolkits, methodology, and application guidelines. Together with their assigned mentor, they will determine the most suitable toolkits to implement during the stakeholder collaboration event/s. Applicants may choose to: (1) launch a social media campaign to raise public awareness on a particular issue; (2) organize and lead a co-creation session to develop a strategy collaboratively; (3) engage with local institutions to foster education and awareness on environmental topics. Through this process H2O will serve as supportive sounding board, offering feedback and guidance to enhance and refine the plans.

Table 10 - Blockchain Traceability Compliance Labelling (TCL)

Blockchain Traceability Compliance Labelling (TCL)

Technical Description

iMERMAID will use a blockchain to ensure data integrity and traceability with robust and trustworthy infrastructure to increase credibility and operations of the main industries (agro, pharmaceutical, textile, etc) as a main upstream Marine polluter. TCL will secure providers full integrity of their data by defining which data exposes at fine grain and taking part in the transactions as peers. Access control is guaranteed at the context ledger by the usage of the public blockchain infrastructure, whereas the scalability and performance are ensured with the proof of stake algorithm, energy efficient DLT with very low-cost transitions.

Image

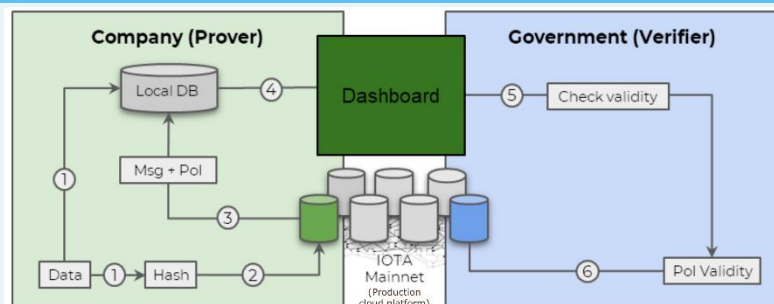

<p>Application</p>	<p>This technology can be integrated by using APIs to facilitate data from sensors that will be collected and stored on the Ledger to ensure compliance and made data integrity check possible. All iMERMAID data coming from sensors available in the iMERMAID use cases will be written in the public Ledger. The data can be accessed over the Ledger Explorer which can be linked to individual datasets. TCL is constructed in the following way: data collection APIs, cloud infrastructure with dashboard and the Blockchain layer. Data collection APIs collects data obtained from various external sources, e.g., from sensors that are developed within the iMERMAID project, or third-party project. The data are visualised with the TCL dashboard and each dataset has a link to a public Ledger that provides the original data in human readable format. The main application of TCL would be to integrate the data from sensors, or other sources that requires traceability and integrity, and compliance check in a user-friendly way.</p>
<p>Ideal End-User</p>	<p>All the types of users of sensing/monitoring, characterization, treatment and remediation innovative solutions listed above in this section, including the ones just performing manual measurements and testing and having a need to record them on a reliable, tamper-proof, secure immutable distributed ledger.</p>
<p>Preliminary Actions</p>	<p>Main requirements and conditions for the selected third-party applicant are: 1) stable and secure internet/intranet access, and 2) general ability to invoke and use the exposed platform API endpoints for interaction with the TCL blockchain, and the Ledger Explorer for integrated data access.</p>
<p>Access During FSTP Programme</p>	<p>The open call applicant can propose using the TCL in their project to ensure integrity of the data and ensure emission and regulatory compliance of the specific industry or other potential polluter. The integration with the TCL can be twofold: 1) API integration if new sensors are introduced; 2) data can be already integrated (i.e., PFAS data which are send remotely will be directly integrated in TCL). The TCL will be fully operational from December 2024.</p>

Table 11 – Data analysis based on remote satellite images applied to local scenarios

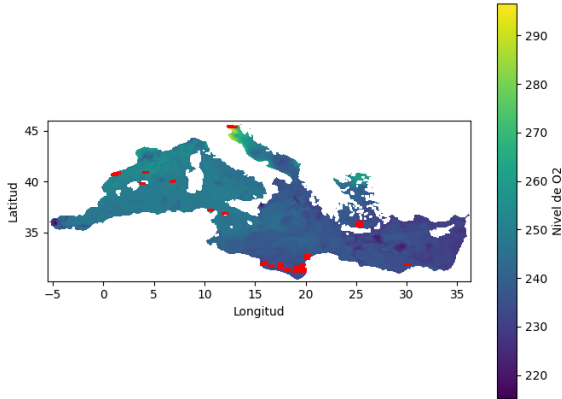
Data analysis based on remote satellite images applied to local scenarios	
Image	
Technical Description	<p>The software combines advanced remote sensing methodologies and data analysis techniques to examine maritime traffic patterns and water quality in the Mediterranean Sea. It utilizes satellite imagery from the Copernicus Sentinel-2 and PRISMA hyperspectral satellites to assess environmental parameters such as turbidity, and pollution indicators. By applying statistical and machine learning models, the software explores potential correlations between spectral data and observed water conditions. High-resolution imagery and hyperspectral data enhance its ability to provide detailed environmental assessments, supporting efforts in monitoring and preserving marine ecosystems.</p>
Application	<p>The maritime and environmental monitoring software is designed for diverse applications in maritime and environmental sectors. It supports tasks such as evaluating water quality and analysing maritime traffic, offering valuable insights for port authorities, environmental agencies, and research institutions. The system aids in identifying high-traffic areas and detecting pollutant trends in sensitive regions. By providing data-driven assessments, it helps stakeholders address environmental challenges and improve maritime operations. Its adaptable design ensures it can be tailored to different geographic and operational contexts, enabling solutions for environmental management and maritime planning.</p>
Ideal End-User	<p>The software is intended for organizations and entities requiring detailed maritime and environmental monitoring capabilities. Potential users include port authorities focused on optimizing traffic management, environmental agencies monitoring pollution levels, and research institutions studying marine ecosystems. Private sector entities, such as shipping companies, industrial operators near coastal areas, and fishing enterprises, can also benefit from its functionality in improving compliance and fostering sustainable practices. Additionally,</p>

governments and non-governmental organizations involved in environmental policy and maritime governance may find its tools valuable for supporting data-driven decision-making.

Preliminary Actions

Before deploying the maritime monitoring software, primary goals should be outlined, such as analysing pollutant patterns or streamlining maritime traffic. Relevant data sources, such as satellite imagery and historical maritime records, should be identified and configured for integration into the system. Establishing workflows for automated data handling and preprocessing, tailored to specific regions or operational needs, is essential. A robust technical infrastructure, including compatible GIS tools and API frameworks, supports smooth integration and scalability.

Access During FSTP Programme

Participants in the FSTP (Financial Support to Third Parties) programme will gain structured access to the maritime monitoring software and training tailored to their specific objectives.

4.0 iMERMAID Use-case specifications

iMERMAID will deploy and demonstrate its solutions in 5 scenarios in the Mediterranean region. This will provide the groundwork for expanding iMERMAID solutions to combat chemical pollution from where it originates to where it ends up.

The scenarios include:

- Agrichemical contaminants, pharmaceutical contaminants, heavy metals, oil, and PFAS.
- Industrial and municipal wastewater treatment plants (WWTP)
- Mediterranean Sea basin

This section details the five use cases and explains the iMERMAID methodology for defining and executing them. The methodology can serve as a guide for applicants, assisting them in developing their own use cases.

4.1 Use-case 1 – Demonstrating innovative solutions for the removal of contaminants from agricultural wastewater

Location: San Esteban de Litera, Spain

Agricultural chemicals, like pesticides, enter water bodies through runoff, causing significant pollution. In the EU, France, Spain, and Italy are major consumers. The Water Framework Directive sets pesticide quality standards in surface water; however, many areas exceed these limits.

San Esteban de Litera is a town located in the North-East of Spain, which wastewater treatment plant aims to return to the environment water of the same quality as the one it had before the abstraction. The WWTP is designed for 1,042 population equivalents, treating 250 m³ per day, and counts on a biological treatment extended with aeration, plus a decanter.

The WWTP receives and treats jointly wastewater coming from different sources, including household water and water from industries. Derived from both types of wastewaters, a variety of micropollutants are expected in the influent and even the effluent of the WWTP due to the recalcitrant behaviour of these compounds to conventional biological treatments. These contaminants include pharmaceuticals and personal care products, hormones, endocrine disruptors as well as disinfection products and contaminants contained in toxic spills coming from industry. In Spain, the high importance of the agricultural activity in the area favours the presence of pesticides in wastewater, supposing a problem for the quality of water and it's necessary to develop solutions for their removal.

Use Case 1 will demonstrate a solution for the remediation of agricultural wastewater. The primary objectives are to deploy and demonstrate the developed water remediation system based on Pulsed Discharge Plasma (PDP) to treat wastewater and eliminate hazardous pollutants such as pesticides, herbicides, fertilizers and other chemicals. In addition, Use Case 1 will include a monitoring system for the CoECs control, considering organic pollutants as target molecules.

By using the iMERMAID Pulsed Discharge Plasma system, Use Case 1 aims to eliminate pollutants without additional chemicals (reactive reagents are produced by the plasma itself), reduce energy consumption, and treat contaminants at the source, thus reducing pollution upstream. The main approach of the technology consists of providing practical tools for on-site treatment of wastewater, to address contamination directly at the source. This will allow to distribute the weight of water treatment over the territory and to deal with critical spills close to the point of entry and avoid affecting the working of the WWTP and polluting waterbodies.

Before deploying the solution for the removal of chemical pollution, the first steps addressed by Use Case 1 consists of an exhaustive characterization of wastewaters in San Esteban de Litera. Once the characterization has been performed, the definition of technical requirements and the integration of the PDP technology will be carried out with the pre-existing facility of Use Case 1 WWTP. For that purpose, iMERMAID consortium will use auxiliary elements (pumps, pipes, probes...) low-CAPEX solutions and will make some adjustments for construction, as legislation project for implementation of PDP technology in WWTP. Once transported and installed, the PDP system will be demonstrated for at least 1 year (plus 4 months for technology set up), in order to cover all seasonal necessities. The system will help avoid pollution in freshwater which is put back to the river after proper treatment upstream, hence minimizing marine pollution downstream.

Expected impacts:

- Demonstrate up to 95% efficiency in degrading agricultural pollutants with the PDP system.
- Assess real-time pollutant sensor framework performance for wastewater monitoring.
- Achieve over 50% reduction in transferring pollutants from agriculture to water bodies.

4.2 Use-case 2 – Demonstrating innovative solutions for the removal of pharmaceutical contaminants

Location: Kalaat Al Andalouss, Tunisia

Pharmaceutical industry effluents typically receive limited treatment before being discharged into the environment or municipal sewage systems, primarily through the conventional Activated Sludge Process (ASP). Trace amounts of active pharmaceutical ingredients may enter the environment post-use, posing potential risks by contributing to drug-resistant bacteria and fungi.

In this use case scenario, iMERMAID remediation solution will be demonstrated at a pharmaceutical company in Kalaat Al Andalouss, Tunisia, to assess the removal efficiencies of pharmaceutical organic pollutants using both conventional ASP and an innovative microfluidic system, aiming to enhance treatment effectiveness.

Electrochemical sensors will be developed to analyse active pharmaceutical contaminants, we selected three molecules, the most impactful ones to be measured by sensors (Ibuprofen, Ketoprofen and Diclofenac).

In this case, a membrane system (prefiltration by Reverse Osmosis System) will be demonstrated for one month with a maximum flow rate of 1 m³/day, followed by a microfluidic system developed as part of the project to assess the removal of emerging pharmaceutical contaminants.

The activities planned as part of Use-case 2 are:

- Performance Monitoring and optimisation of the WWTP Operation
- Preparation of list of targeted molecules
- Selection of target molecules for analysis and treatment
- Coordination with technology providers
- Sampling campaigns to collect pharmaceutical wastewater
- Obtention of the quantification results from partners
- Developing and validation of an Analytical method on site for the quantification of pharmaceuticals in wastewater, this method will serve as comparison method to the results provided by the electrochemical sensors to assess the efficiencies of the remediation solutions.
 - Site study and technical assessment (Definition of technical requirements)
 - Preparatory work for the installation of technologies: Identifying the necessary site preparation and the additional equipment (Tanks, Pipes, Pumps, ...). Acquisition and connection of the pilot plant developed as part of the project for a maximum flow rate of 1m³/day (microfluidic system) and pre-filtration system
 - Analysis campaign using the sensors developed as part of the project & validation of the technology
 - Test of complementary treatments with the pilot
 - Validation of technologies
 - Proposal of solutions for the reuse of treated wastewater and optimal water management in general
- Conclusions of the use case

Expected impacts:

- Achieve >95% degradation of emerging pharmaceutical contaminants from industrial effluents.
- Contribute to over 50% reduction in pharmaceutical pollutants at their source compared to conventional techniques, meeting EU permissible limits.
- Evaluate the performance of the monitoring box for efficient measurements of selected relevant chemicals in real wastewater treated directly at the source.

4.3 Use-case 3 – Demonstrating innovative solutions for the removal of heavy metals

Location: Metropolitan City of Turin, Italy

Human activities and industrial processes often release effluents containing heavy metals such as cadmium, lead, and copper. Many of the heavy metals are hazardous even in low concentrations and the accumulation of these pollutants poses a significant threat to the environment and water ecosystems. In order to minimize heavy metal pollution, their removal from wastewater, before being released in water bodies, is very important. At the same time, also monitoring these metals is of primary importance. Thus, preventing any release into the environment is crucial, and recognizing this, the EU has established discharge limits for many heavy metals.

In this scenario Use Case 3 will be deployed to demonstrate the monitoring and removal of heavy metals from wastewater through innovative technologies. The pilot is a WWTP (wastewater treatment plant) located in the Metropolitan Area of Turin, designed for a population of 9000 inhabitants, which receives wastewater both from domestic and industrial discharge. The WWTP consists of an initial screening of gross solids, skimming of fats, oils and grease. This is followed by a denitrification process in an anoxic environment and a primary oxidation. The process continues with a secondary oxidation and sedimentation. Finally, the disinfectant is dosed into the outlet channel of the secondary sedimenters.

This WWTP has been selected for Use Case 3 since high concentration of Zinc where sporadically detected at wastewater plant inlet.

The aim of the pilot is i) to perform a continuous monitoring on the metal content managed by the WWTP and to eventually detect concentration peaks by means of the electrochemical inorganic sensor developed by UNIFI (Zn, Cd, Pb, Cu); ii) to remove heavy metals (Zn, Cu, Al) from wastewater by means of WF's 4D Scavenger technology; iii) to verify the performances of the monitoring system and the treatment technology.

Both the technologies and the monitoring system should be able to deal with wastewater (also by means of proper pre-treatments), that is characterized by high (and variable) concentration of BOD, COD and STSS.

To evaluate the feasibility of the UC, some preliminary considerations have been taken into account:

- **Definition of WWTP to deploy technologies:** Identification of a WWTP with potential or well-note issue related to high concentrations of heavy metals.

- **Screening of targets heavy metals:** In order to define target heavy metals quantification of the metal content in different stages of the treatment plant is needed. These activities can be performed by analysing historical already available data and by means of specific sampling campaigns. Moreover, the characterization of the content of other substances that can interfere with the sensor analysis and the treatment technology is important. Parameters such as BOD and SST should be quantified in order to define if a pre-treatment stage is necessary.

- **Periodic meetings with WWTP manager:** Periodic meetings with the WWTP's manager are needed in order to design the Use Case. Specific needs should be taken into account and inspections should be performed in order to evaluate the possible location for the technology installation (availability of space, electric power, etc.).

- **Definition of installation requirements:** On the basis of the preliminary acquired information (sampling campaign, site characteristics, etc.), the installation requirement should be defined by means of periodical meetings with the technological providers (definition of requirements for water entering into the pilot/monitoring system - maximum acceptable concentration of BOD, COD, TSS - , provision of electric power, internet connection, positioning of the technology, waste disposal, etc.).
- **Planning necessary works for site preparation:** Connection of the pilot to the WWTP, consulence for installation of pre-filtration step (if needed), availability of budget for site preparation, provision of reagents, definition of a waste management plan, etc.
- **Realization of necessary works for site preparation:** Connection of the pilot to the WWTP, , hydraulic connection, provision of electric power, etc.
- **Technologies installation and piloting activities:** Transportation of the technologies to the pilot, set-up, personnel training, maintenance and operational activities.
- **Validation of the installed technology:** Monitoring campaigns will be performed in order to evaluate the removal efficiency of the pilot and the accuracy of the measurement performed by the heavy metal sensor.
- **Conclusion of the Use Case:** Uninstallation of the provided technology, final waste disposal and report of achieved results.

On the basis of all the preliminary considerations above mentioned, the 4D Scavenger will be tested at WWTP outlet in Brandizzo for a 1-month period starting from March 2025. On the basis of the performed sampling campaigns, it has been verified that BOD and SST concentrations are low enough to be managed directly from the pre-filtration system of the pilot technology. The Heavy Metal box will be tested in the same period and will be integrated in the pilot unit, taking advantage of the pre-filtration step already available. During the pilot period, the Heavy metal box will be tested both to monitor the 4D Scavenger inlet (after the filtration step – stage 1), both to monitor the 4D Scavenger outlet (stage 2).

Expected impacts:

- Metals removal capacity > 95% in wastewater with metals concentration > 0,5 mg/l and >90% in wastewater with metals concentration < 0,5 mg/l.
- Implementation of a real-time pollutant sensor framework for monitoring Pb, Cd and Cu up to 5 µg/l and Zn up to 10 µg/l.
- Efficient treatment of pollutants ensuring a proactive approach to environmental protection.

4.4 Use-case 4 – Monitoring platform in the Mediterranean Sea

Location: Limassol, Cyprus

This use case will demonstrate the monitoring of chemical pollutants of emerging concern at sea. The use case is a moored buoy which serves as a research fixed platform for contributing to marine observation and marine data exchange.

It incorporates both batteries and electrical panels with the necessary wiring for the installed sensors. The battery capacity, which is recharged by four PV panels, supports an additional electrical load. The electrical panel has been specifically designed to accommodate additional sensors, which can be placed within the internal space of the buoy. The buoy's floatation, balancing weight, and mooring system are

also designed to allow the integration of additional equipment. The buoy's datalogger is designed with more input slots, allowing the integration of additional sensors through network cable pins. Data collected by these sensors are transmitted via 4G cellular communications to the cloud system of CMMI.

During the iMERMAID project, the involved partners will explore the perspective of monitoring organic pollutants, crude oil derivatives and heavy metals, and also employ the technology for monitoring oil spills using satellite data. This is an assimilation that combines satellite and in-situ data with all available information from numerical models describing the ocean dynamics, observations, and prior information.

The activities that participants can follow to replicate the use case:

- installation of the buoy
- sampling activities
- integration of sensors (to define)
- piloting activities
- data collection

Expected impacts:

- Examine of the potential to replicate the MB with an 80% chance of success.
- Evaluate the combined performance of satellite data and sensors for a specific pollutant, achieving a 90% match.

4.5 Use-case 5 – Demonstrating innovative solutions for the removal of organic contaminants from landfill leachates

Location: Crete, Greece

Sanitary landfill leachate is a strongly polluted wastewater with a variety of components. It is characterized by high organic and inorganic pollutant concentrations and is extremely toxic if it is disposed untreated to the environment.

The Leachate Treatment Plant (LTP) of Pera Galini Sanitary Landfill, Crete is a tertiary treatment plant that receives the leachate produced by the Sanitary Landfill (100 m³/d) and includes the following treatment stages: a) a physical/chemical process including coagulation, flocculation and Dissolved Air Flotation b), a physical/biological treatment based on a Membrane BioReactor and c) a purification process with Reverse Osmosis (RO) technology. The effluent after degasification and chlorination is used for irrigation and recirculation to the landfill for enhancing its performance.

The objective of the Use Case 5 is to demonstrate the feasibility of scaled up version of upstream organic CoEC pollution remediation as a solution for preventing chemical pollution in the Mediterranean basin. The Microfluidic water remediation system which is an innovative solution for the removal of organic contaminants from landfill leachates will be deployed and will be tested for its efficiency in removing selected micropollutants (Bisphenol A, Bentazone, and Propamocarb) for the effluent before RO treatment stage. Utilizing advanced oxidation processes within a microfluidic water treatment system, the identified micropollutants will be degraded through photocatalysis. No modification of the environmental license of the Sanitary Landfill is needed due to the pilot character of the remediation technology infrastructure.

The microfluidic remediation technology will be employed as a tertiary treatment system (before RO) for handling approximately 1m³/d for an iterative operation of 1 month. In the same use case, electrochemical sensors will be developed for monitoring a) the selected micropollutants (BPA, PFOA, Bentazon, Propamocarb) in the RO influent before and after the remediation system and b) heavy metals in the RO effluent. The applicability of all sensors will be also demonstrated.

A series of analyses in treated and untreated leachate samples was important to be performed during the first 6 months to finalize the contaminant list, involving organic compounds parameters, chemical and physicochemical parameters, as well as necessary bioassays (i.e., toxicity tests) and heavy metal analysis. BisphenolA (BPA), a chemical compound primarily used in the manufacturing of various plastics, is identified as the predominant phenolic molecule among all four selected micropollutants in landfill leachate and treated effluent. After the selection of the targeted contaminants, the integration of the remediation technology will be carried out with the pre-existing facility of Use Case 5 LTP.

To evaluate the feasibility of the use case, except the determination of the targeted pollutants, an additional consideration is the characterization of the content of other substances that can interfere with the sensor analysis and the treatment technology. Parameters such as BOD and TSS should be quantified to define if a pre-treatment stage is necessary as the presence of TSS could interfere with the efficient operation of the system. Same is the case for the sensor systems; a prefiltration system is necessary. Low-CAPEX solutions will also be needed for auxiliary elements (pipes, prefiltration system, tank, etc.) for the connection of both sensors and remediation system to the LTP facilities. Finally, the area demanded for the installation of the technologies (sensors and tanks) is < 6 m².

Expected impacts:

- Up to 95% efficiency of microfluidic system in the leachates micropollutant reduction.
- Installation of real-time pollutant sensors for the monitoring of the effluents.
- After treatment > 50% reduction in the selected pollutants transfer to the mediterranean basin.

5.0 iMERMAID Use-case checklist

The following checklist provides an example of the steps taken to frame the iMERMAID use-cases. This check-list can support third parties in developing their own use-cases understanding better the type of information needed, pre-setting and the processes required for successful planning and management of a use-case development. Applicants should develop their use-cases according to the 9-month time-frame of the iMERMAID technical support programme and the availability of the solutions as described in Section 3

Table 12 - iMERMAID Use-case checklist

iMERMAID Use-case checklist		
#	Title	Description
1.	Use-case objectives	Define the goals of this use case. Example: The primary goal of this use case is to develop a system that can analyse marine data to predict weather patterns.

2.	Location where the use-case will be applied	Provide the geographical location where the use-case will be developed, including any specific characteristics related to the use-case.
3.	Type of facility	Briefly describe the facility where the use-case activities will take place
4.	Activity of the facility	Briefly describe the function of the facility
5.	Processes included in the facility	What does the facility do e.g. measurement of contaminants; purification; conversion etc. Provide specific parameters and indicators.
6.	Target compounds and parameters that could be monitored or treated	Provide description of the target CoECs.
7.	Impact of the target compounds	What is the expected impact if these pollutants are not monitored and treated.
8.	Technology that can be installed and validated in the Use Case	Link the iMERMAID solution that might be tested considering the needs of the use-case and the availability of the selected solution. Preliminary work done throughout the participation of the beneficiary in the iMERMAID programme should lead to showcasing the feasibility, replicability and scale up of the solution/s.
9.	Use-case description	Provide a description of scenarios to be addressed in this use case. Example: Scenario 1: Analysing data to predict storms..., Scenario 2: Providing weather forecasts for a coastal event...
10.	Specific requirements that need to be in place for the execution of the use-case	User requirements (<i>Documented needs and expectations that a system must meet for its users</i>) Functional requirements (<i>Describe WHAT the system is expected to do based on the user requirements</i>) Non-functional requirements (<i>Describe HOW the system will be assessed. Example: Accuracy of 3-day weather prediction, Data processing time, User satisfaction with the system</i>)
11.	Use case Key Performance Indicators	Describe how the scenarios and requirements will be validated.
12.	Existing constraints	Mention any limitations or restrictions such as technology,

		budget, time, etc. Example: Budget limitation of €100,000, Project must be completed within 9 months, Use existing sensor technology.
13.	Regulatory and technical alignments	<ul style="list-style-type: none"> 1) Regulations and directives that the use case must comply with 2) Data management 3) Risk assessment 4) Any needs for regulatory approval to be defined with the timeframe to acquire these
14.	Stakeholder identification	Briefly outline what each stakeholder needs from this use case. Example: meteorologists need accurate weather predictions, marine researchers need access to historical data, local authorities need real-time weather updates for safety measures.
15.	Expected outcome	What should be the end result of this use-case (short – after the project ends to medium term – in 3 years' time)
16.	Timeline	Provide a roadmap of activities with the time of execution for the duration of the 9-months participation in the iMERMAID programme

6.0 Conclusion

This document serves as an informative resource detailing the iMERMAID methodology, solutions, and approach to deploying the internal use-cases. It complements Annex 1 iMERMAID Guidelines for applicants by providing a comprehensive understanding of the innovative solutions and use-case specification offered by the iMERMAID consortium. The information provided herein should support third parties in elaborating their own use cases.

The Mediterranean Sea and its surrounding regions support a diverse variety of essential socioeconomic activities. It is one of the highly exploited water ways and the influence of anthropogenic activities on its marine habitats and ecosystems has grown significantly since the industrial revolution. Because of this, the Mediterranean Sea basin is very vulnerable to chemical contamination and build-up. To safeguard the Mediterranean Sea basin from contaminants for emerging concerns (CoEC), iMERMAID will integrate, coordinate, and synergize innovative preventive, monitoring, and remediation solutions. iMERMAID will build an evidence-based multidimensional framework that will guide policymaking and transform societal perceptions to reduce CoEC usage, emissions, and pollution. Furthermore, next generation sensor and remediation solutions will be developed within iMERMAID to monitor and remove prioritized chemicals from its source while reducing upstream pollution. iMERMAID builds an ideal interdisciplinary team by bringing together prominent SMEs, researchers, regulators, and innovation professionals who have been essential in improving the knowledge and awareness of CoEC. Beyond state-of-the-art techniques, iMERMAID will strive to strengthen regulations against CoEC, expand economic possibilities and competitiveness, improve the standard of living for EU residents, while preventing the accumulation of chemical pollution in the Mediterranean Sea basin. iMERMAID will empower the efforts to create a zero pollution, contaminant free waters by enabling the Chemical Strategy's goals to become a practical reality.



**Funded by
the European Union**